



Crossing and Encroachment Guide and Requirements – US

Document Owner:	Enterprise Manager of Damage Prevention, S&R Lands & ROW
Revision Date:	January 30, 2025

Crossing and Encroachment Guide and Requirements – US



Table of Contents

1	Introduction.....	1
2	Crossing and Encroachment Activities – What You Need to Know.....	1
2.1	Activities Requiring Consent.....	1
2.2	Non-Crossing or Encroachment Activities that Require Consent.....	2
2.3	Early Consultation with Enbridge for Larger Projects.....	2
2.4	Regulatory Requirements.....	3
2.4.1	Laws and Regulations.....	3
2.4.2	Ground Disturbance Zone.....	3
3	Applying for Consent.....	3
3.1	Ways of Applying for Written Consent.....	3
3.1.1	Crossing and Encroachment Application and Consent.....	3
3.1.2	Crossing and Encroachment On-Site Application and Consent.....	4
3.2	Drawing Requirements.....	4
3.2.1	Drawing Requirements for Permanent Installations.....	4
3.2.2	Drawing Requirements for Temporary Activities.....	7
3.2.3	Typical Crossing Drawings.....	9
3.3	Application Submission.....	17
3.4	Application Review and Written Consent.....	18
4	Requirements Before Construction – One-Call Centers and Locate Requests.....	18
4.1	One-Call Centers.....	18
4.2	One-Call Locate Requests.....	20
5	Requirements During Construction.....	20
5.1	General Requirements.....	20
5.1.1	Fully Executed Consent on Site.....	20
5.1.2	Stop Work.....	20
5.1.3	Accidental Contact with Enbridge Facilities.....	20
5.1.4	Securing Unattended Open Excavations.....	21
5.1.5	Protection of Enbridge Signage and Test Stations.....	21
5.2	Locate and Identify Subsurface Facilities.....	21
5.2.1	Positive Identification of Enbridge Facilities.....	21
5.2.2	Vacuum Excavating Requirements.....	22
5.2.3	Enbridge Inspection of Exposed Pipeline.....	22
5.3	Excavating.....	22
5.3.1	Excavation Plan.....	22

Crossing and Encroachment Guide and Requirements – US



5.3.2	Excavation Requirements	22
5.4	Augering and Pile Driving Requirements	23
5.5	Material Storage Requirements	23
5.6	Lifting Loads Over Enbridge Facilities.....	23
5.7	Temporary Protective Structures.....	23
5.7.1	Temporary Protective Structure Designs.....	23
5.7.2	Adjacent Structure or Foundation Protection	24
5.7.3	Shoring and Trench Boxes	24
5.7.4	Temporary Crossing Ramps and Air Bridges.....	24
5.7.4.1	When Ramps and Air Bridges are not Required.....	24
5.7.4.2	Temporary Crossing Ramps	24
5.7.4.3	Air Bridge Requirements.....	25
5.8	Backfilling and Compaction Requirements	25
5.9	Subsurface Installations	26
5.9.1	Subsurface Installation Requirements.....	26
5.9.2	Open Cut Installations	26
5.9.2.1	Above an Enbridge Facility Requirements	26
5.9.2.2	Below an Enbridge Facility Requirements.....	27
5.9.3	Boring Subsurface Installation Requirements	27
5.9.3.1	Technical Requirements for Boring.....	27
5.9.3.2	Boring Operation General Requirements	28
5.9.4	Drainage Tile Crossing Enbridge Pipelines Requirements	28
5.10	Above-Grade Installations.....	28
5.10.1	General Requirements for Above-Grade Installations.....	28
5.10.2	Signs, Fence Posts and KP/MP Marker Installations.....	29
5.10.3	Resurfacing and Re-graveling	29
5.10.4	Ditch Restoration	29
5.10.5	Minor Berms	29
5.10.6	Spreading or Replacing Soil Fill Material	30
5.10.7	Topsoil Stripping/Leveling and Clearing/Grading	30
5.10.8	Ancillary Installation, Above-Ground Installation or Temporary Storage.....	30
5.10.9	Agricultural Ground Disturbance	30
5.10.10	Vegetation Control	30
5.10.11	Vehicle Crossings – Wheeled and Tracked Vehicles	30
5.10.12	Road Crossings.....	31

Crossing and Encroachment Guide and Requirements – US



5.10.13	Railway Crossings.....	31
5.11	Power and Communication Installations	32
5.11.1	Consent Limitation.....	32
5.11.2	Overhead Power Less Than 60 kV and Communication Installation	32
5.11.3	Power Line Data Requirements for Transmission Power	33
5.11.3.1	Power Lines More Than 60 kV	33
5.11.3.2	Information Required for Each Transmission Power Line.....	34
5.12	Geophysical – Blasting, Quarrying and Seismic.....	36
5.13	Site Restoration Requirements	36
6	Emergency Situations and Enbridge Emergency Contact Numbers	36
6.1	Notice of Access	36
6.2	Enbridge Definition of Emergency	36
6.3	One-Call Centers	37
6.4	Enbridge Emergency Contact Numbers	37
7	Definitions	38

Crossing and Encroachment Guide and Requirements – US



List of Tables

Table 1: Subsurface and Surface Ground Disturbance Activities.....	2
Table 2: Contact Information for US One-Call Centers.....	18
Table 3: Overhead AC Distribution Power Line Horizontal Clearances for Distribution Pipelines	32
Table 4: High-Voltage AC Power Line Horizontal Clearances from Structures, Grounding and Anchors for Distribution Pipelines	34
Table 5: Enbridge Crude Oil and Liquids Emergency Numbers for the US	37
Table 6: Enbridge Gas and Midstream Emergency Numbers for the US.....	37
Table 7: Enbridge Renewable Power and Power Transmission Emergency Numbers for the US	37

List of Figures

Figure 1: Ground Disturbance Zone in the US	3
Figure 2: Road Crossing – Typical Drawing	9
Figure 3: Facility Crossing – Typical Drawing	10
Figure 4: Test Lead Connection for Steel Pipeline – Typical Drawing.....	10
Figure 5: Railway Crossing – Typical Drawing.....	11
Figure 6: Crossing Ramp – Typical Drawing	12
Figure 7: Crossing Ramp with Mats – Typical Drawing.....	13
Figure 8: Air Bridges – Typical Drawing	13
Figure 9: Resurfacing or Re-graveling – Typical Drawing.....	14
Figure 10: Ditch Restoration – Typical Drawing.....	14
Figure 11: Minor Berms – Typical Drawing.....	14
Figure 12: Above-Ground Installations – Typical Drawing.....	15
Figure 13: Tracked Vehicles – Typical Drawing.....	15
Figure 14: Wheeled Vehicles – Typical Drawing.....	16
Figure 15: Compaction Equipment – Typical Drawing.....	17
Figure 16: Exposure Points for Bends.....	21

Crossing and Encroachment Guide and Requirements – US



Revision History

Date	Rev #	Revised by	Reviewed by	Approved by	Revision Details
October 19, 2021	0	Libby Graham		Ken Goulart	Issued
March 2, 2023	1	Ken Goulart		Ken Goulart	Revised
October 4, 2023	1.1	Emily Bridge		Ken Goulart	Revised
January 30, 2025	1.2	Emily Bridge Kelly Daly	Emily Bridge Kelly Daly	Ken Goulart	Revised

1 Introduction

This document is intended to help applicants understand the Enbridge crossing and encroachment application process and related Enbridge requirements, and includes information about:

- what kinds of crossing and encroachment activities on or near Enbridge facilities require consent and the related requirements (see Section 2, [Crossing and Encroachment Activities – What You Need to Know](#))
- information about applying for consent and submitting an application (see Section 3, Applying for Consent)
- contact information for notifying One-Call Centers before construction or work activities begin (see Section 4, Requirements Before Construction – One-Call Centers and Locate Requests)
- key information for during construction and Enbridge requirements (see Section 5, Requirements During Construction)
- information about notifying Enbridge if an emergency occurs (see Section 6, Emergency Situations and Enbridge Emergency Contact Numbers)

Applicants who cannot meet the minimum approved technical requirements outlined in this document may submit alternative proposals to Enbridge for consideration.

2 Crossing and Encroachment Activities – What You Need to Know

2.1 Activities Requiring Consent

To ensure Enbridge pipelines and facilities operate safely, Enbridge should be contacted for an assessment and consent before:

- construction or installation of a new facility across, over, on, along or under an Enbridge facility and/or right-of-way
- operation or movement of vehicles, mobile equipment or machinery across an Enbridge right-of-way, outside of the traveled portion of a highway or public road
- subdivision development across, on, along or over an Enbridge facility and/or right-of-way
- installation of agricultural drainage tile across, on, along or under an Enbridge facility and/or right-of-way

Enbridge also requires notification of the use of explosives within 985 ft (300 m) of an Enbridge pipeline right-of-way. Upon review of blasting plans, Enbridge may issue written consent that contains mitigations to protect its assets.

Specific crossing and encroachment activities that require consent might include, but are not limited to, those shown in [Table 1](#).

Table 1: Subsurface and Surface Ground Disturbance Activities

Subsurface Activities	
<ul style="list-style-type: none"> Installing pipeline or cable by trenching, drilling, boring or augering (see Section 5.4 for augering and pile driving and Section 5.9.3 for boring) Excavating or digging (see Sections 5.1.4, 5.2 and 5.3) 	<ul style="list-style-type: none"> Subsoiling/deep tilling - cultivation greater than 1.5 ft (0.45 m) (see Section 5.10.9) Using explosives (see Sections 5.12) Installing drainage tile (see Section 5.9.4)
Surface and Aerial Activities	
<ul style="list-style-type: none"> Installing fence posts, bars, rods, pins, anchors or pilings (see Sections 5.10.1 and 5.11.3) Maintaining existing applicant facilities that affect Enbridge assets, land and/or right-of-way Topsoil stripping/leveling and clearing/grading (see Section 5.10.7) Clearing and stump removal, vegetation management and burning (see Section 5.10.10) Installing above-ground installations, such as sheds, above-ground pools and landscaping (see Section 5.10.8) Using an Enbridge easement/right-of-way area for temporary workspace 	<ul style="list-style-type: none"> Ditching work for water management or reprofiling existing ditches (see Section 5.10.4) Constructing a new public or private road, pathway, parking lot or railway, or widening an existing road (see Section 5.10.1) Installing berms or earthworks that alter the existing ground profile (see Section 5.10.5) Installing overhead power lines, wires or cables (see Section 5.11) Regrading a gravel road (see Section 5.10.3) Grinding and milling asphalt or concrete (see Section 5.10.3) Using or traversing the right-of-way for access (see Section 5.10.11) Storing equipment or material, including trailers, boats, bales, wood piles and vehicles on the right-of-way (see Section 5.10.8)

2.2 Non-Crossing or Encroachment Activities that Require Consent

Other activities also require Enbridge consent, and could include such things as:

- using an Enbridge owned road

2.3 Early Consultation with Enbridge for Larger Projects

Enbridge should be consulted early in the design phase regarding proposed subdivisions, road, pipeline and/or utility projects, railroads and municipal landscaping.

Additionally:

- for subdivisions, Enbridge highly recommends that its right-of-way be used as a passive green space or as part of a linear park system
- roads and utilities may be permitted to cross and/or run parallel to the right-of-way
- projects such as pedestrian pathways, gardens, land contouring, shrubbery and tree planting may be permitted if they do not impede Enbridge access along its right-of-way for operational and/or maintenance activities. Enbridge written consent will specify the permitted landscaping requirements.

2.4 Regulatory Requirements

2.4.1 Laws and Regulations

The applicant must ensure that all work associated with its application complies with local, state and federal rules, laws and regulations.

2.4.2 Ground Disturbance Zone

Figure 1 shows the Enbridge ground disturbance zone for the United States (US), including the blasting assessment zone.

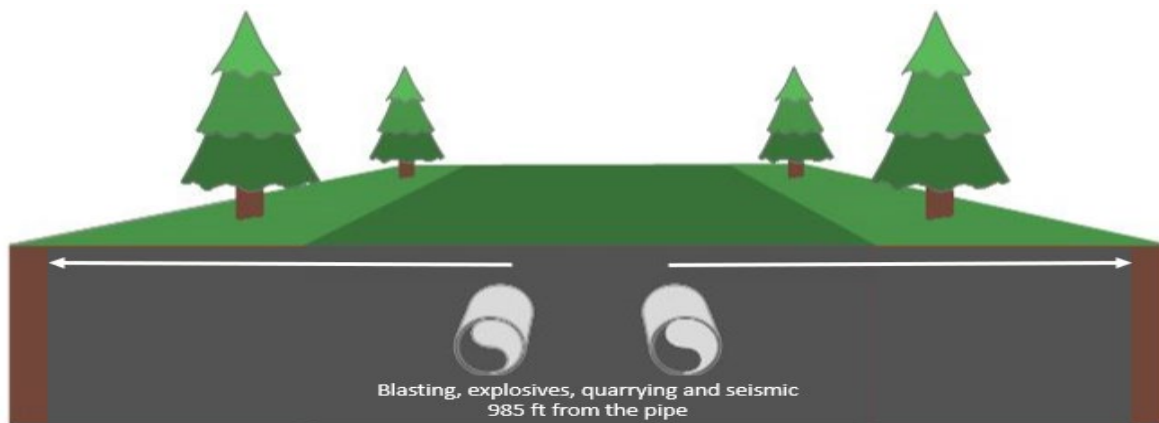

Figure 1: Ground Disturbance Zone in the US

3 Applying for Consent

3.1 Ways of Applying for Written Consent

Written consent from Enbridge must be received before any crossing or encroachment activities begin. The two ways of getting Enbridge consent are either by getting consent:

- from an Enbridge Crossings department (see Section 3.1.1, Crossing and Encroachment Application)
- from an Enbridge Field Representative at a field location (see Section 3.1.2, Crossing and Encroachment On-Site Application)

3.1.1 Crossing and Encroachment Application and Consent

The applicant must submit a written request by completing a “Crossing and Encroachment Application,” together with the applicable drawing(s), to the respective Enbridge Crossings department listed in Section 3.3, [Application Submission](#). These applications are reviewed and approved through the Enbridge Crossings departments.

The drawing(s) must be prepared in accordance with the minimum standards provided in Section 3.2, [Drawing Requirements](#). Enbridge’s vehicle crossing information (see Section 3.2, [Drawing Requirements](#)) must also be completed for any vehicle or mobile equipment crossing applications.

Visit enbridge.com/crossings for a copy of the “[Crossing and Encroachment Consent](#),” which includes standard terms and conditions, including but not limited to such things as environmental obligations, liability and indemnity, and insurance requirements.

3.1.2 Crossing and Encroachment On-Site Application and Consent

Certain crossing and encroachment activities might be eligible for approval by an Enbridge Field Representative at a field location. To qualify for consideration of field approval, all proposed activities listed below must meet all the applicable technical requirements outlined in related subsections of Section 5, Requirements During Construction:

- installing some subsurface installations (see Section 5.9.2 and Section 5.9.3):
 - coaxial cable
 - non-metallic pipelines NPS 12 and less
 - fiber optic cable
 - electrical cable less than 750 V
- using air bridges (see Section 5.7.4.3)
- installing drain tile (see Section 5.9.4)
- spreading or replacing soil fill material (see Section 5.10.6)
- installing fence posts, KP/MP markers and signage (see Section 5.10.2)
- conducting maintenance of roads, pathways and sidewalks (resurfacing or re-graveling) (see Section 5.10.3)
- doing ditch restoration (see Section 5.10.4)
- installing minor berms (see Section 5.10.5)
- installing ancillary or above-ground installations (see Section 5.10.8)
- conducting agricultural ground disturbance (see Section 5.10.9)
- conducting vegetation control (see Section 5.10.10)
- using some wheeled and tracked vehicles (see Section 5.10.11)
- overhead distribution power and communication lines (see Section 5.11.2)

Any proposed on-site activities not meeting the requirements in Section 5, Requirements During Construction, must be approved using the “Crossing and Encroachment Application” noted above.

Visit enbridge.com/crossings for a copy of the “Crossing and Encroachment On-Site Application and Consent,” which includes standard terms and conditions, including but not limited to such things as environmental obligations, liability and indemnity, and insurance requirements.

3.2 Drawing Requirements

3.2.1 Drawing Requirements for Permanent Installations

For all permanent crossings, complete a) Drawing Requirements for all Permanent Crossings. Then identify the type of facility being crossed, see b) to f) below, and provide the related information on the drawings.

a) Drawing Requirements for all Permanent Crossings

Items to Include on all Permanent Drawings

- Plan number, including any revision number and the respective date
- North arrow
- Scale
- Legend or properly labeled on the site plan
- Location indicator, including:
 - legal land description
 - property index number (PIN)
 - Lat/Long coordinates in decimal degrees e.g. 58.269856 -112.568967
 - crossing location of each pipeline affected
- Plan view of the whole quarter section or affected area including:
 - lot lines and road limits
 - proposed facilities (including e.g., curbs, footing, guard rails, guy wires, poles and fences) with tie
 - location of cathodic test lead terminals, if known and applicable
- Cross section view and/or profile view including:
 - for surface structures, show the profile along pipeline(s) with the highest elevation
 - for underground facilities, show the profile along the facility
 - property lines and pipeline(s)
 - drill path plans for subsurface installations, including alignment and entry and exit angles
 - unsupported span (m/ft) of Enbridge pipeline for open-cut installations
- Crossing angle
- Crossing location clearly labeled
- Identification of all affected Enbridge facilities and right(s)-of-way, if applicable
- Method of installation (see Section 7, Definitions)
- Minimum clearance from Enbridge facility

Note that other items, e.g., depth of cover or right-of-way(s), might be required as a revision after preliminary drawings are reviewed.

b) Pipe, Cable, Wire or Line

Items to Include on Pipe, Cable, Wire or Line Drawings

- Pipe diameter
- Pipe material
- Product conveyed
- Cathodic protection system (if applicable)
- Cable, wire or line size
- If cable, wire or line is within a conduit, conduit material and size
- Voltage, if cable, wire or line is electric

c) Above-Grade Installations

For example, road, path, parking lot or railway.

Items to Include on Above-Grade Installation Drawings

- Dimensions of road, path or parking lot
- Elevation at ditch
- Elevation at the center of the road, path or parking lot
- Surface material
- Road, path type or usage
- Changes to right-of-way
- Lat/Long coordinates in decimal degrees e.g. 58.269856 -112.568967 of the beginning and end of the limits of the crossings in the right-of-way
- GPS coordinates (decimal format) of the beginning and end of the limits of the crossings
- Maximum excavation/milling/removal of material from above the pipeline

d) Overhead Distribution Power

For transmission power lines, see Section 5.11.3, Power Line Data Requirements for Transmission Power for additional drawing requirements.

Items to Include on all Overhead Distribution Power Drawings

- Pole number(s)
- Location of e.g., pole, guy wire or anchors, with GPS coordinates and distance from Enbridge pipeline
- Method of installation of e.g., pole, guy wire or anchors
- Vertical clearance to ground or grade
- Width of the applicant's right-of-way easement
- Voltage

e) Drainage Tile

Items to Include on Drainage Tile Drawings

- Location of tile (the entry point into the easement, crossing point over the facility and the exit point or the parallel distance from the facility)
- Incremental cost analysis, if applicable
- Tile diameter
- Tile material
- Method of installation

f) Berms or Earthworks that Change the Cover Profile

For example, excavations and ditching.

Items to Include on Berms and Earthworks Drawings

- Dimensions including width, depth or height and length of earth material being installed or removed
- Type of earth or material

3.2.2 Drawing Requirements for Temporary Activities

For all temporary crossings, complete g) Drawing Requirements for all Temporary Activities. Then identify the type of facility being crossed, see h) to n) below, and provide the related information on the drawings.

g) Drawing Requirements for all Temporary Activities

Items to Include on all Drawings for Temporary Activities

- Plan number, including any revision number and the respective date
- North arrow
- Scale
- Legend or properly labeled on a site plan
- Location indicator, including:
 - legal land description
 - PIN
 - GPS coordinates (decimal format)
- Plan view of the whole quarter section or affected area
- Temporary activities (including location) clearly labeled
- Identify all affected Enbridge facilities, right-of-way(s) and/or easement ownership. Enbridge facilities must be field verified.
- Soil type, if known

h) Workspace

Items to Include on Workspace Drawings

- Location
- Measurement of workspace
- Purpose

i) Blasting – Including Seismic and Geophysical Activities

Items to Include on Blasting Drawings

- Charge layout (including number of units/lines)
- Type and material specification of source
- Charge weight per hole
- Distance from Enbridge facilities
- Project name and prospect name (US, or if applicable)

j) Access of Right-of-Way

Items to Include on Access of Right-of-Way Drawings

- Location
- Kilometer or mile usage of right-of-way
- Width of access
- Egress/ingress points
- Complete the vehicle crossing information (see l), m) and n) for wheeled, tracked and compaction requirements below)

k) Enbridge Owned Road Use

Items to Include on Enbridge Owned Road Use Drawings

- Indicate road(s) to be used
- Kilometer or mile usage
- Reason required
- Frequency of use
- Complete the vehicle crossing information (see l), m) and n) for wheeled, tracked and compaction requirements below)

l) Wheeled Vehicles

Items to Include on Wheeled Vehicle Drawings

Complete all information in the typical drawing section for wheeled vehicles.

- For road legal vehicles, submit a typical drawing including the table in Section 3.2.3, Typical Crossing Drawings ([Figure 14: Wheeled Vehicles – Typical Drawing](#)) for each of the heaviest axle load per grouping by axle configuration, e.g., the heaviest single, heaviest tandem, heaviest tridem vehicle.
- For non-road legal vehicles, submit a typical drawing including the table in Section 3.2.3, Typical Crossing Drawings ([Figure 14: Wheeled Vehicles – Typical Drawing](#)) for each vehicle.

m) Tracked Vehicles

Items to Include on Tracked Vehicle Drawings

- Submit a typical drawing including the table in Section 3.2.3, Typical Crossing Drawings ([Figure 13: Tracked Vehicles – Typical Drawing](#)) for each tracked vehicle.

n) Compaction Equipment

Items to Include on Compaction Equipment Drawings

- Submit a typical drawing including a table in Section 3.2.3, Typical Crossing Drawings (Figure 15: Compaction Equipment – Typical Drawing) for each piece of compaction equipment.

3.2.3 Typical Crossing Drawings

See below typical drawings for:

- road crossing
- facility crossing
- test lead connection for steel pipeline
- railway crossing
- crossing ramps
- crossing ramp with mats
- air bridges
- resurfacing or re-graveling
- ditch restoration
- minor berms
- above-ground installations
- wheeled vehicles
- tracked vehicles
- compaction equipment

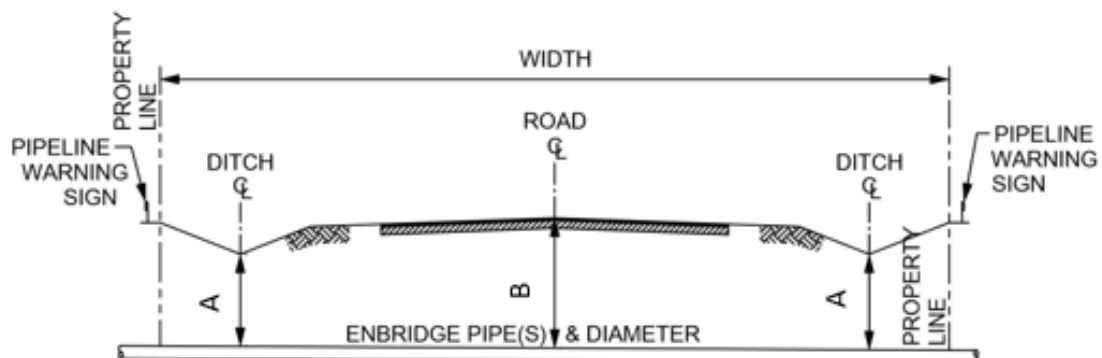

Figure 2: Road Crossing – Typical Drawing

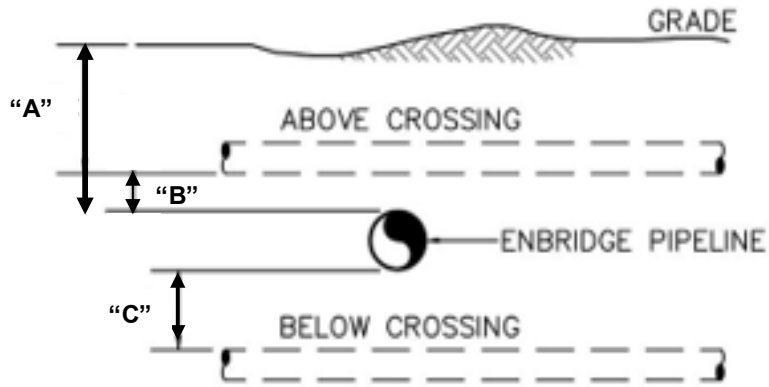

Figure 3: Facility Crossing – Typical Drawing

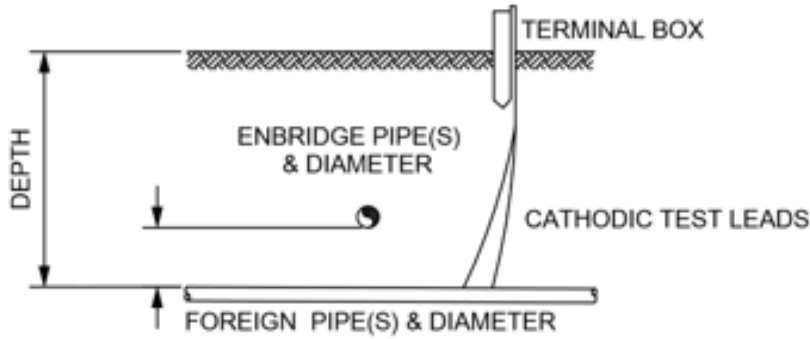
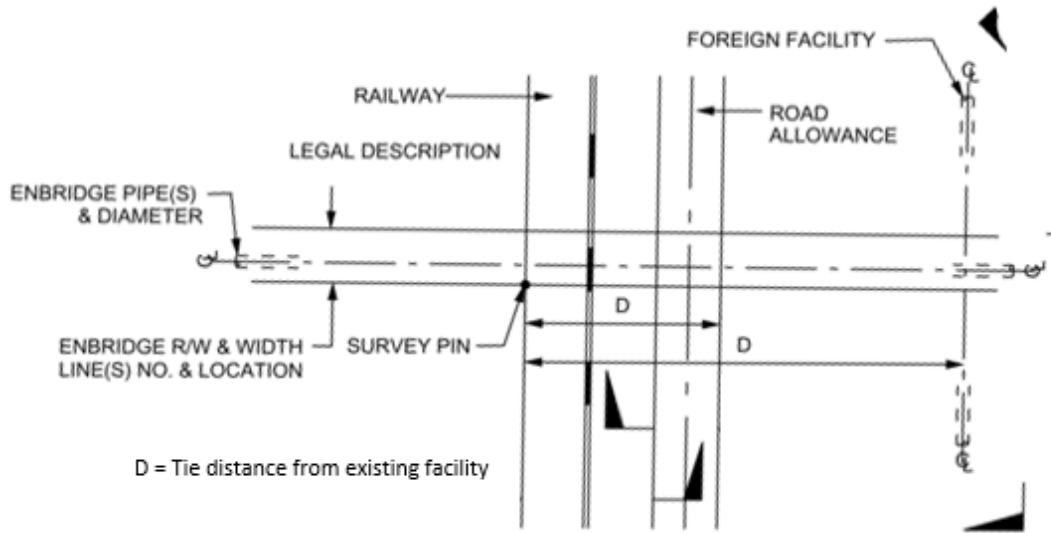
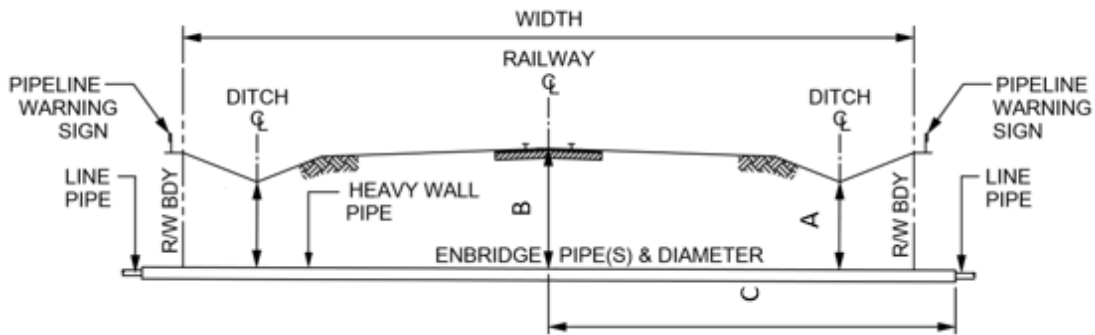

Figure 4: Test Lead Connection for Steel Pipeline – Typical Drawing

Crossing and Encroachment Guide and Requirements – US



Location Plan



Note: Because Enbridge pipelines operate under high pressure, an Enbridge Representative(s) must be present during construction.

Figure 5: Railway Crossing – Typical Drawing

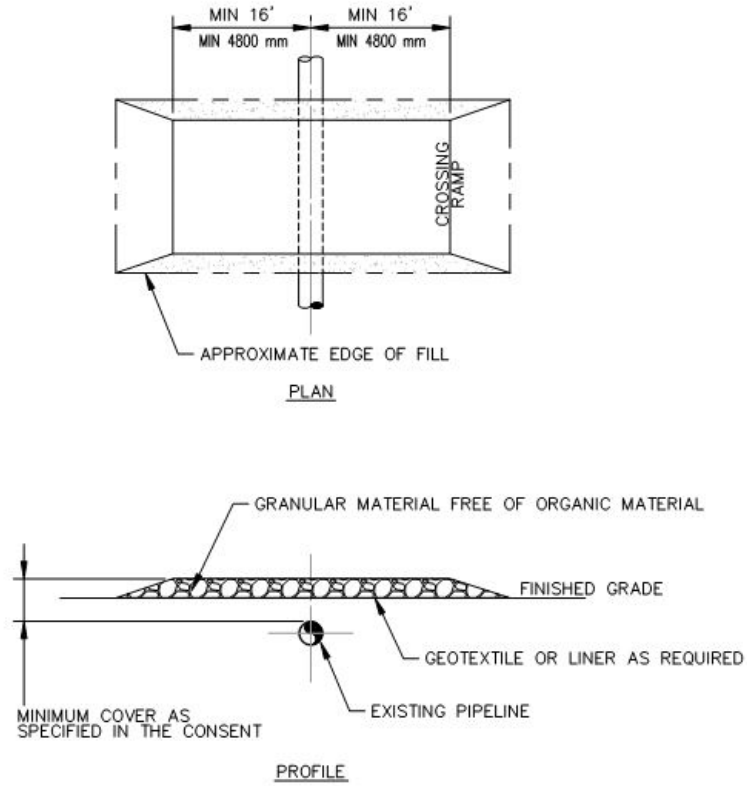

Figure 6: Crossing Ramp – Typical Drawing

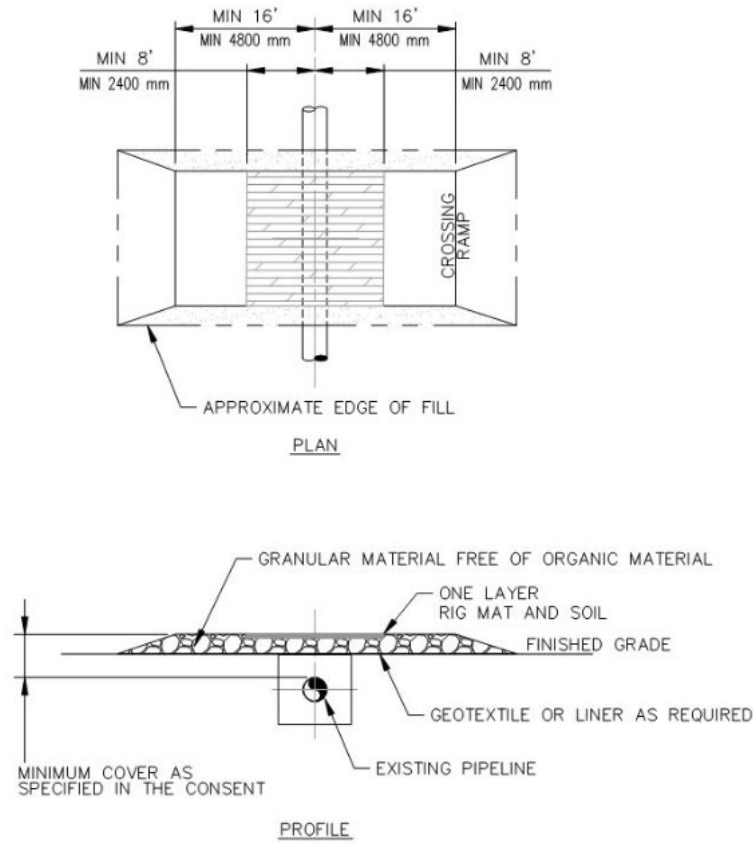

Figure 7: Crossing Ramp with Mats – Typical Drawing

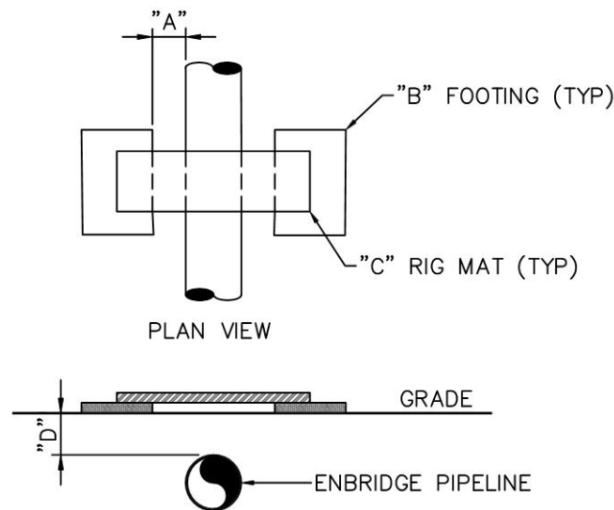
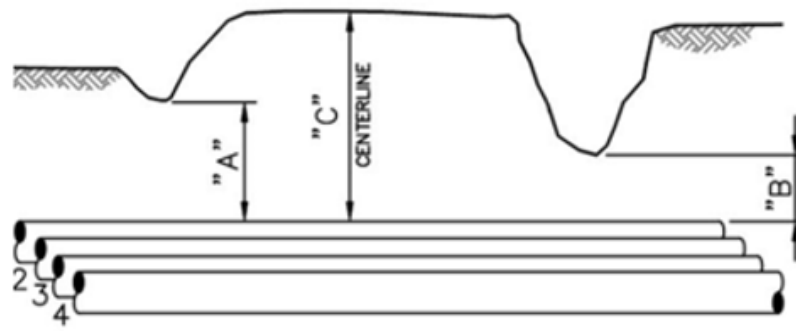

Figure 8: Air Bridges – Typical Drawing



All measures to the top of pipe

Figure 9: Resurfacing or Re-graveling – Typical Drawing

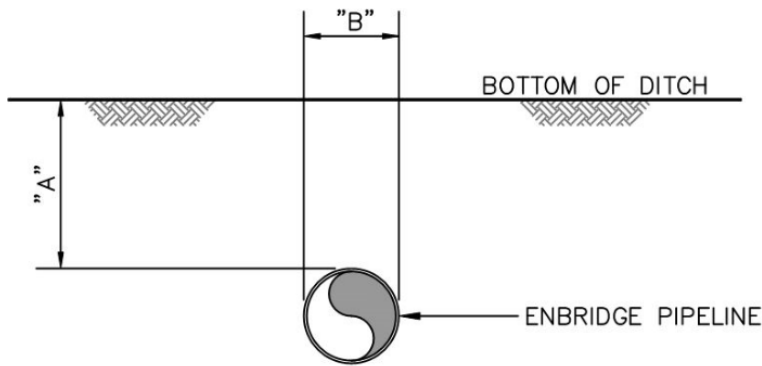

Figure 10: Ditch Restoration – Typical Drawing

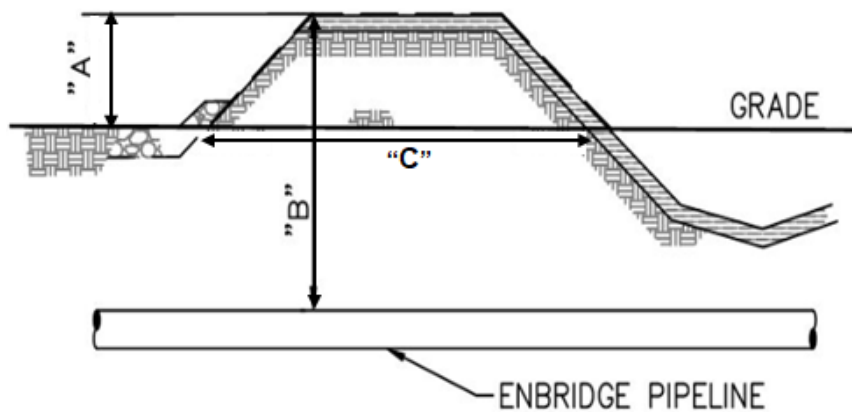

Figure 11: Minor Berms – Typical Drawing

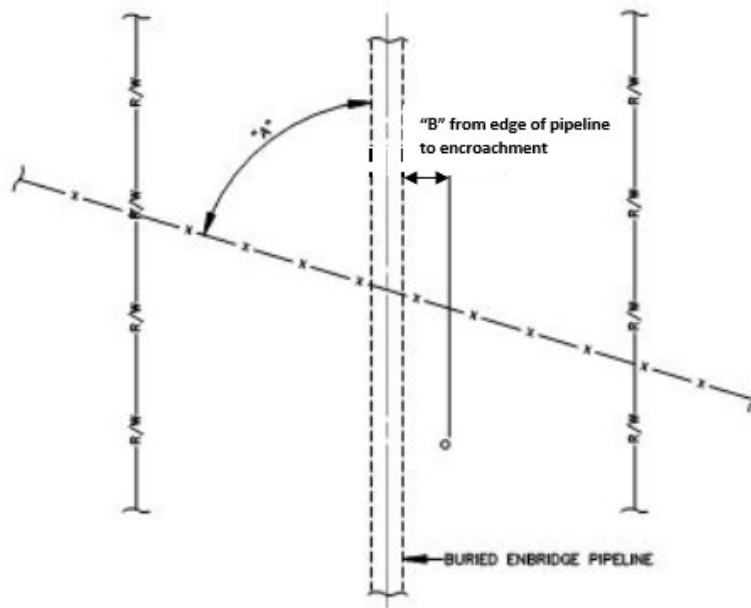
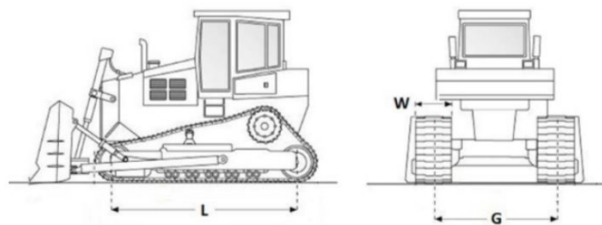

Figure 12: Above-Ground Installations – Typical Drawing



Manufacturer:		Model:	
Equipment description:			
Fully loaded gross vehicle weight:			<input type="checkbox"/> kg <input type="checkbox"/> lb
	Track Shoe Width (see W in figure):	Track Length on Ground (see L in figure):	Track Gauge on Center (see G in figure):
Track	<input type="checkbox"/> mm <input type="checkbox"/> in.	<input type="checkbox"/> mm <input type="checkbox"/> in.	<input type="checkbox"/> m <input type="checkbox"/> ft

Figure 13: Tracked Vehicles – Typical Drawing

Crossing and Encroachment Guide and Requirements – US



Road Legal Requirements

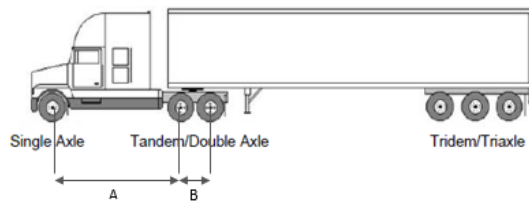

Complete the following table for the heaviest axle load per grouping that is road legal. NOT for non-road legal vehicles or construction equipment.

Non-Road Legal Requirements

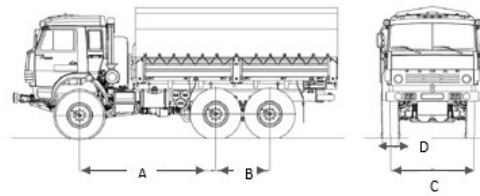

Complete the following table for each vehicle that is not road legal.

Manufacturer:						Model:			
Equipment description:									
Fully loaded gross vehicle weight:						<input type="checkbox"/> kg <input type="checkbox"/> lb			
Axle Grouping	Max. Loaded Weight PER Axle	Number of Tires PER Axle	Individual Tire Width (see D above)	Tire Pressure	Distance between Tire Set Centerlines (see C above)	Centerline Distance to Previous Axle (see A and B above)			
Steering	<input type="checkbox"/> kg <input type="checkbox"/> lb		<input type="checkbox"/> mm <input type="checkbox"/> in.		<input type="checkbox"/> mm <input type="checkbox"/> in.	<input type="checkbox"/> mm <input type="checkbox"/> in.			
2nd	<input type="checkbox"/> kg <input type="checkbox"/> lb		<input type="checkbox"/> mm <input type="checkbox"/> in.		<input type="checkbox"/> mm <input type="checkbox"/> in.	<input type="checkbox"/> mm <input type="checkbox"/> in.			
3rd	<input type="checkbox"/> kg <input type="checkbox"/> lb		<input type="checkbox"/> mm <input type="checkbox"/> in.		<input type="checkbox"/> mm <input type="checkbox"/> in.	<input type="checkbox"/> mm <input type="checkbox"/> in.			
4th	<input type="checkbox"/> kg <input type="checkbox"/> lb		<input type="checkbox"/> mm <input type="checkbox"/> in.		<input type="checkbox"/> mm <input type="checkbox"/> in.	<input type="checkbox"/> mm <input type="checkbox"/> in.			
5th	<input type="checkbox"/> kg <input type="checkbox"/> lb		<input type="checkbox"/> mm <input type="checkbox"/> in.		<input type="checkbox"/> mm <input type="checkbox"/> in.	<input type="checkbox"/> mm <input type="checkbox"/> in.			
6th	<input type="checkbox"/> kg <input type="checkbox"/> lb		<input type="checkbox"/> mm <input type="checkbox"/> in.		<input type="checkbox"/> mm <input type="checkbox"/> in.	<input type="checkbox"/> mm <input type="checkbox"/> in.			
7th	<input type="checkbox"/> kg <input type="checkbox"/> lb		<input type="checkbox"/> mm <input type="checkbox"/> in.		<input type="checkbox"/> mm <input type="checkbox"/> in.	<input type="checkbox"/> mm <input type="checkbox"/> in.			
Total Axle Weight									

Figure 14: Wheeled Vehicles – Typical Drawing

Crossing and Encroachment Guide and Requirements – US



Select or sketch the correct loading diagram							Other (sketch here)
	Manufacturer:			Model:			
Equipment description:							
Dimensions (per circled/selected diagram)							
Drum length:	L=	<input type="checkbox"/> mm <input type="checkbox"/> in.	Drum diameter:	D=	<input type="checkbox"/> mm <input type="checkbox"/> in.		
Wheelbase:	B=	<input type="checkbox"/> mm <input type="checkbox"/> in.	Tire width:	A=	<input type="checkbox"/> mm <input type="checkbox"/> in.		
Gauge (on center):	G =	<input type="checkbox"/> mm <input type="checkbox"/> in.	Tire pressure:		<input type="checkbox"/> psi <input type="checkbox"/> kPa		
Other dimensions from sketch:							
Loading (include units):							
Total operating weight:						<input type="checkbox"/> smooth drums <input type="checkbox"/> padfoot drums	
Static weight on front drum/axle:							
Static weight on rear drum/axle:							
Centrifugal force: high vibration							
low vibration							

Figure 15: Compaction Equipment – Typical Drawing

3.3 Application Submission

3.3.1 Download and Complete the Application Form

- Save the form to your computer, open it in Adobe to fill out the PDF, save a completed copy and email it to us at crossingsUS@enbridge.com; or,
- Download and print the [application form](#) from enbridge.com/crossings, fill it out, scan, or photograph it and email it to us at crossingsUS@enbridge.com.

3.4 Application Review and Written Consent

After applying for written consent, Enbridge will review the proposed installation(s) and/or temporary activity(ies) application to ensure that the proposed work will not pose a risk to existing Enbridge facilities, and to ensure that any access required to existing facilities for maintenance or in an emergency will not be impeded.

Some applications might require a further engineering assessment that will require additional time to review the proposed installation(s) and/or temporary activity(ies) before Enbridge issues a consent. All efforts will be made to provide a written consent within an appropriate timeframe. Please ensure that your application is complete (refer to other sections of this document for items relevant to your proposed activity) and your application request is submitted with ample lead time.

4 Requirements Before Construction – One-Call Centers and Locate Requests

4.1 One-Call Centers

Call or click before you dig!! Enbridge is a member of Call or Click Before You Dig, a quick, free and easy communication service that notifies member companies of proposed activities so that underground infrastructure can be safely marked with flags, stakes or paint before work begins.

Before putting a shovel in the ground, whether it is in your backyard or a commercial job site, you must submit a locate request to safely identify any underground facilities by contacting your local One-Call Center as shown below.

Table 2: Contact Information for US One-Call Centers

Region	Telephone	Website
Alabama	1-800-292-8525 or 811	www.al811.com
Arkansas	1-800-482-8998 or 811	www.arkonecall.com
Colorado	1-800-922-1987 or 811	www.co811.org
Connecticut	1-800-922-4455 or 811	www.cbyd.com
Delaware	1-800-282-8555 (DE), 1-800-441-8555 (ESMD) or 811	www.missutility.net
Florida	1-800-432-4770 or 811	www.sunshine811.com
Georgia	1-800-282-7411 or 811	www.georgia811.com
Illinois	1-800-892-0123 or 811	www.illinois1call.com
Indiana	1-800-382-5544 or 811	www.indiana811.org
Iowa	1-800-292-8989 or 811	www.iowaonecall.com
Kansas	1-800-344-7233 or 811	www.kansasonecall.com
Kentucky	1-800-752-6007 or 811	www.kentucky811.org
Louisiana	1-800-272-3020 or 811	www.laonecall.com
Maine	1-888-344-7233 or 811	www.digsafe.com

Crossing and Encroachment Guide and Requirements – US



Region	Telephone	Website
Maryland	1-800-257-7777 or 811	www.missutility.net
Massachusetts	1-888-344-7233 or 811	www.digsafe.com
Michigan	1-800-482-7171 or 811	www.missdig.org
Minnesota	1-800-252-1166 or 811	www.gopherstateonecall.org
Mississippi	1-800-227-6477 or 811	www.ms811.org
Missouri	1-800-344-7483 or 811	www.mo1call.com
Montana	1-800-551-8344 (One-Call Center) or 1-800-424-555 or 811 (Montana Utilities Underground)	www.mt1call.com
Nebraska	1-800-331-5666 or 811	www.ne1call.com
New Hampshire	1-888-344-7233 or 811	www.digsafe.com
New Jersey	1-800-272-1000 or 811	www.nj1-call.org
New Mexico	1-800-321-2537 or 811	www.nm811.org
New York	1-800-962-7962 or 811 (New York State, except NYC) or 1-800-272-4480 (NYC)	www.udignny.org (New York State, except NYC) or www.newyork-811.com (NYC)
North Carolina	1-800-632-4949 or 811	www.nc811.org
North Dakota	1-800-795-0555 or 811	www.ndonecall.com
Ohio	1-800-362-2764 or 811	www.oups.org
Oklahoma	1-800-522-6543 or 811	www.OKIE811.org
Oregon	1-800-332-2344	www.digsafelyoregon.com
Pennsylvania	1-800-242-1776	www.paonecall.org/
Rhode Island	1-888-344-7233 or 811	www.digsafe.com
South Dakota	1-800-781-7474 or 811	www.sdonecall.com
Tennessee	1-800-351-1111 or 811	www.tenn811.com
Texas	1-800-344-8377 or 811	www.lonestar811.com
Vermont	1-888-344-7233 or 811	www.digsafe.com
Virginia	1-800-552-7001 or 811	www.va811.com
Washington	1-800-424-555 or 811	www.callbeforeyoudig.org/washington /index.asp
Washington DC	202-265-7177 or 811	www.missutility.net

Crossing and Encroachment Guide and Requirements – US



Region	Telephone	Website
West Virginia	1-800-245-4848 or 811	www.wv811.com
Wisconsin	1-800-242-8511 or 811	www.diggershotline.com
Wyoming	1-800-849-2476 or 811	www.onecallofwyoming.com

4.2 One-Call Locate Requests

Applicants must place a One-Call locate request with the appropriate One-Call Center and ensure Enbridge has completed a locate before beginning any ground disturbance activity.

In the following situations, a new locate request is required:

- when surface markings become dislodged, removed or unrecognizable
- if the One-Call ticket expires
- if a new contractor or subcontractor is retained to conduct ground disturbance work in the area, as transfer (piggybacking) of existing tickets is **not** permissible
- if there is a change in the scope of work (i.e., change in the excavation area or duration of a project)

Note: Additional locates beyond the locate boundary might be required to verify alignment.

5 Requirements During Construction

5.1 General Requirements

5.1.1 Fully Executed Consent on Site

Applicants must ensure a fully executed copy of the consent is on site during construction and before notice is provided to an Enbridge Representative.

5.1.2 Stop Work

Enbridge Representatives have the authority to stop work at any time due to safety, environmental or operational concerns and/or unforeseen circumstances or emergency situations. For example, Enbridge Representatives can stop work if they:

- have a concern for safety or security of Enbridge assets, the environment and the public
- have concern for pipeline integrity
- are required to leave the work site

The Enbridge Representative will determine when activities can recommence.

5.1.3 Accidental Contact with Enbridge Facilities

Immediately notify an Enbridge Representative if:

- your equipment accidentally comes into contact with an Enbridge facility
- you think your equipment might have contacted an Enbridge facility

Note: Even a small scratch or dent in a pipeline's coating can impact long-term safety of the pipeline and must be assessed by Enbridge. See Section 6 for emergency contact information.

5.1.4 Securing Unattended Open Excavations

Unattended open excavations, trenches, potholes and boreholes must be barricaded or fenced off as appropriate, depending on conditions. If any Enbridge facility is left exposed overnight, steel traffic plates and/or an orange safety fence, or an alternative Enbridge-approved method of securing the site, must be used to protect the public, the environment and Enbridge facilities.

5.1.5 Protection of Enbridge Signage and Test Stations

If applicable, all Enbridge signage and test stations must be protected during construction. If any of them need relocation due to construction, this work must be only performed by, or under the supervision of, an Enbridge Representative and at the cost of the applicant.

5.2 Locate and Identify Subsurface Facilities

5.2.1 Positive Identification of Enbridge Facilities

Enbridge requires that all buried facilities are positively located and identified to Enbridge's satisfaction before planned ground disturbance activities occur within 16 ft (5 m) of any Enbridge facility and/or within the right-of-way. In addition to the One-Call locate request, the applicant must positively identify any Enbridge facility by one or more of the following:

- hand digging
- vacuum excavating (air-vacating or hydro-vacating)

The applicant must ensure that:

- positive identification is to a sufficient width to visually identify (positively identify) the location, direction/alignment, depth, size and type of any Enbridge below-grade facilities
- all bends at a minimum are positively identified at the beginning, center and end of the bend to ensure that the profile is accurately identified (see [Figure 16](#)) (some bends may require additional exposure holes)
- locations that require more than one exposure hole must not have exposure holes spaced more than 75 ft (23 m) apart (center-to-center)

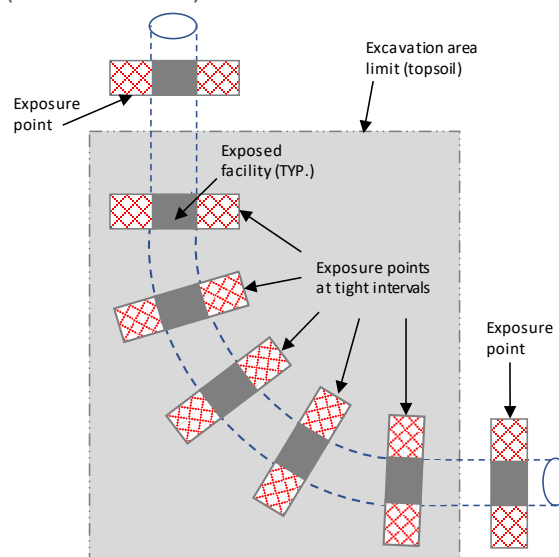

Figure 16: Exposure Points for Bends

5.2.2 Vacuum Excavating Requirements

Vacuum excavating activities contain inherent risks and the appropriate controls must be followed to avoid damage to Enbridge facilities.

For all vacuum excavating activities, the applicant must ensure to:

- use a neoprene or equivalent tip on the vacuum end to eliminate the possibility of damage to the Enbridge facility
- remove any loose rock embedded in the sides of the excavation that could fall on the Enbridge facility when the vacuum excavation activity is complete

For hydro-vacuum excavating (hydro-vac) activities, in addition to the above requirements, the applicant must:

- ensure the working water pressure does not exceed 2500 psi (17,250 kPa)
- reduce pressure to less than 1500 psi (10,350 kPa) and limit water temperature to 100°F (38°C) when excavating within 1 ft (0.3 m) of any Enbridge facility
- ensure the Enbridge facility is not continually contacted by direct spray once it has been sighted or exposed

5.2.3 Enbridge Inspection of Exposed Pipeline

At any location where an Enbridge pipeline is exposed, the applicant must allow Enbridge the opportunity to inspect the condition of the pipeline.

5.3 Excavating

5.3.1 Excavation Plan

An excavation plan must be reviewed and approved by the Enbridge Representative before mechanical excavation can occur. The excavation plan may be a written document or a verbal discussion with the Enbridge Representative. At a minimum, the excavation plan must include, but not be limited to the:

- excavator set-up position in relationship to the Enbridge asset
- need for benching to level the excavator
- required excavation depth and length
- sloping and shoring requirements
- ingress/egress ramp locations
- minimum clearance requirements for mechanical equipment
- pipeline location and depth
- spoil pile location
- compliance with applicable federal and state regulations

5.3.2 Excavation Requirements

The use of excavation equipment in the Enbridge right-of-way, or off the right-of-way and within 10 ft (3 m) of an Enbridge pipeline (measured from the centerline of the pipeline), must be evaluated by Enbridge.

For excavations, the applicant must:

- ensure a bar is welded onto backhoe bucket teeth and the side cutters must be removed. In exceptional circumstances where buckets with teeth and dozers with ripper teeth are required, then documented approval by the Enbridge Representative is required.
- **not** in any manner use any Enbridge facility as a platform while excavating
- **not** use mechanical excavation within 2 ft (0.6 m) of any Enbridge facility, including protruding material that extends outside the bucket (e.g., frozen material, rocks or concrete)
- **not** use manually operated jack hammers or hoes equipped with jack hammers directly over any Enbridge facility

5.4 Augering and Pile Driving Requirements

Augering and pile driving activities are not allowed within the right-of-way.

Augering and pile driving outside the right-of-way or within 33 ft (10 m) of any below-grade Enbridge facility requires review and approval by Enbridge.

5.5 Material Storage Requirements

Storage of material, or temporary parking of equipment or vehicles is **not** permitted over any Enbridge right-of-way unless written approval is received from Enbridge.

If soil stockpiles are approved to be placed on the right-of-way, Enbridge requires that stockpiles must:

- be stored at least 3 ft (1 m) from the edge of a working excavation
- not have a spoil pile slope greater than 45 degrees from the horizontal
- be limited to 5 ft (1.5 m) in height
- have a physical barrier, approved by Enbridge, placed on the ground before placing soil on top of it

5.6 Lifting Loads Over Enbridge Facilities

When working in close proximity to any Enbridge facility, the applicant must ensure:

- equipment used for lifting, including cranes, and associated rigging are properly maintained, checked, rated and sized correctly for the intended load
- the equipment is not set up within 10 ft (3 m) of any Enbridge facility
- the outriggers are not set up within 10 ft (3 m) of any Enbridge facility
- lifts are not directly over, or swing over, an exposed Enbridge facility
- outrigger pads that are appropriately sized are used
- the crane boom does not extend over above-grade Enbridge facilities during lifting operations
- that if lifts must occur over an Enbridge facility, the proposed lift plan must be submitted for an engineering assessment to determine appropriate mitigation requirements to protect the buried facility from a dropped load risk

5.7 Temporary Protective Structures

5.7.1 Temporary Protective Structure Designs

The applicant must provide engineered designs related to temporary protective structures occurring within the Enbridge right-of-way or within 16 ft (5 m) of any Enbridge facility.

5.7.2 Adjacent Structure or Foundation Protection

The applicant must ensure that a professional engineer be consulted to review the stability of any Enbridge structure or foundation that might be affected by an excavation or trench. If required, a temporary protective structure must be designed, constructed and installed to support the structure or foundation in accordance with the specifications of a professional engineer.

5.7.3 Shoring and Trench Boxes

Applicants must ensure that:

- all shoring and trench boxes are installed and removed as per the manufacturers' specifications and in accordance with applicable regulations
- before a trench box is installed, a copy of the engineering certificate or a stamped engineering drawing, including assemble and disassemble instructions, is:
 - sent to Enbridge
 - available on the worksite
 - identifiable to that trench box
- trench boxes stacked in deep excavations are adequately secured to one another in accordance with the engineered design
- only professionally engineered hoisting points and hoisting connectors or manufacturer approved lifting methods are used to lift trench boxes
- the space between the trench box and the excavation wall is backfilled to limit soil movement in the event of a cave-in

5.7.4 Temporary Crossing Ramps and Air Bridges

5.7.4.1 When Ramps and Air Bridges are not Required

Temporary crossing ramps or air bridges are not required if there is more than 10 ft (3 m) of depth of cover and the vehicle weight is less than 56,000 lb (25,400 kg) per axle or for a tracked vehicle less than 60,000 lb (27,270 kg). Note that some regions might have more stringent weight requirements for specific pipelines.

5.7.4.2 Temporary Crossing Ramps

When deemed required by Enbridge, the applicant must construct temporary crossing ramps in accordance with Figure 6: Crossing Ramp – Typical Drawing and Figure 7: Crossing Ramp with Mats – Typical Drawing in Section 3.2.3, Typical Crossing Drawings.

The applicant must:

- maintain crossing ramps so that rutting or degradation of the ramps does not reduce the required minimum depth of cover
- remove all ramps during demobilization, unless otherwise approved in writing by Enbridge
- remove the complete ramp and restore the area as close as practical to its original condition at the end of construction
- adhere to the minimum depth of cover as specified on the consent
- adhere to the minimum clearances noted in Figure 6 and Figure 7 in Section 3.2.3, Typical Crossing Drawings

- ensure the ramp deck is a minimum of 16 ft (4800 mm) on either side of the center of the pipeline
- when using rig mats, ensure:
 - the ramp deck is a minimum 16 ft (4800 mm) on either side of the center of the pipeline
 - the rig mats are centered over the pipeline and have a minimum span of 8 ft (2400 mm) on either side of the pipeline
- ensure the width of the ramp does not encroach beyond the boundaries set in the consent
- ensure the ramp side slope is not steeper than 1 vertical to 4 horizontal
- ensure the ramp is compacted and has a cross-fall to ensure water will not pond on the ramp causing excessive rutting
- install a geotextile or liner barrier, at the discretion of the Enbridge Representative
- for multiple lines, ensure there is a minimum of 16 ft (4800 mm) clearance from the center of the outer-most pipelines

See Section 3.2.3, Typical Crossing Drawings for ramp drawings (Figure 6: Crossing Ramp – Typical Drawing and Figure 7: Crossing Ramp with Mats – Typical Drawing).

5.7.4.3 Air Bridge Requirements

An air bridge may be approved if the air bridge meets the following criteria, otherwise the applicant needs to submit a design using the “Crossing and Encroachment Application”:

- edge of the footing mat to the edge of the facility is a minimum of 5 ft (1.5 m)
- timber footing mats are 8 ft x 10 ft (2.4 m x 3 m). Using larger steel framed rig mats requires larger footing mats. The width of the ramp must be sufficient to accommodate equipment. Additional footing mats must be staggered so that loads are effectively spread across the footing mats.
- overlap of a rig mat to the footing mat is a minimum of 2 ft (0.6 m)
- ramp is perpendicular to the pipeline

An air bridge may be approved in the field using the “Crossing and Encroachment On-Site Application and Consent” if the air bridge meets the above criteria and the minimum depth of cover is 3 ft (1 m). See Section 3.2.3, Typical Crossing Drawings for an air bridge drawing (Figure 8: Air Bridges – Typical Drawing).

5.8 Backfilling and Compaction Requirements

Backfilling and compaction around an Enbridge facility must be done by, or under the direct supervision of, Enbridge and must adhere to the Enbridge construction and engineering standards.

Within the right-of-way, drive or ride-on compaction and vibratory equipment with the vibratory mechanism engaged is prohibited without an assessment.

Minimum requirements for compaction and vibratory equipment:

- drive or ride-on compaction and vibratory equipment is allowed within 3 ft (1 m) horizontal distanced of a pipeline if all the following conditions are met:
 - no vibratory mechanism engaged
 - less than 20,000 lb (9,072 kg) per axle
 - at least 4 ft (1.2 m) of cover
- hand-held compaction equipment (including vibratory equipment) is allowed:

- within 2 ft (0.6 m) vertical and horizontal clearance of the pipeline
- within 2 ft (0.6 m) vertical and 1 ft (0.3 m) horizontal clearance of the pipeline with approval

If the above requirements are not met, the applicant must complete and submit a “Crossing and Encroachment Application” to the Crossings group for an engineering assessment and approval, and include compaction equipment information in [Figure 15: Compaction Equipment – Typical Drawing](#) in Section [3.2.3, Typical Crossing Drawings](#).

5.9 Subsurface Installations

5.9.1 Subsurface Installation Requirements

The crossing angle for installations must be within 45–90 degrees (with preference for as close to perpendicular as possible). All underground facilities must maintain an even elevation across the entire width of the right-of-way, except for gravity-type facilities or those facilities installed by horizontal directional drill (HDD).

Ensure non-metallic underground facilities, excluding agricultural drain tile, have a tracer line, EMS ball markers, RFID tags or other alternative locate marking method acceptable to industry. Tracer wire is to terminate at a location approved by an Enbridge Representative where it is still accessible for future locating purposes. Tracer wire is to be secured at appropriate intervals to an applicant’s underground pipeline.

High-capacity fibre-optic lines and electric lines must be installed in conduit or casing (Schedule 80 minimum or equivalent) or concrete encasement (dyed red if electrical) with tracer wire. This conduit or casing must be maintained at a minimum of 10 ft (3 m) to each side of any Enbridge facility or the entire width of the Enbridge right-of-way, whichever is the greater distance.

Where the applicant’s facility is a steel pipeline, the applicant must design and install, at a minimum, a cathodic protection test station equipped with two coated cathodic protection test leads connected to the applicant’s facility at the nearest reasonable access location, as determined and approved by an Enbridge Representative. See [Figure 4: Test Lead Connection for Steel Pipeline – Typical Drawing](#).

5.9.2 Open Cut Installations

5.9.2.1 Above an Enbridge Facility Requirements

Technical Requirements

Applicants must:

- achieve a minimum clearance of 2 ft (0.6 m) for cable (TV, telephone or fiber), utility pipelines NPS 12 and less and electrical lines less than 750 V
- use utility warning tape 1 ft (0.33 m) below grade, in accordance with APWA Uniform Color Code, and in the bottom of the trench (color coded to corresponding Enbridge pipeline) across the entire width of the Enbridge right-of-way, unless otherwise directed
- initially add two layers of geotextile material, if an aggregate base is used at the bottom of the proposed trench

Field Approved Activities

Subsurface activities listed below that meet the requirements above may be approved in the field using the “Crossing and Encroachment On-Site Application and Consent,” otherwise the applicant will need to submit a design using the “Crossing and Encroachment Application”:

- cable (coaxial)/telephone
- non-metallic pipelines NPS 12 and less
- fiber optics
- electrical less than 750 V
- drain tile

See Section 3.2.3, Typical Crossing Drawings, for subsurface installations above an Enbridge facility (Figure 3: Facility Crossing – Typical Drawing).

5.9.2.2 Below an Enbridge Facility Requirements

Technical Requirements

Applicants must:

- achieve a minimum clearance of 2 ft (0.6 m), unless otherwise stated
- take appropriate measures to prevent trench/pipe settlement and to take special care to ensure that the compaction between the utility and the Enbridge pipeline is sufficient to mitigate settlement and voids
- ensure the maximum unsupported span is 15 ft (4.5 m) for any Enbridge facility

Field Approved Activities

Subsurface activities listed below that meet the requirements above may be approved in the field using the “Crossing and Encroachment On-Site Application and Consent,” otherwise the applicant will need to submit a design using the “Crossing and Encroachment Application”:

- cable (coaxial)/telephone
- non-metallic pipelines NPS 12 and less
- fiber optics
- electrical less than 750 V

See Section 3.2.3, Typical Crossing Drawings, for subsurface installations above an Enbridge facility (Figure 3: Facility Crossing – Typical Drawing).

5.9.3 Boring Subsurface Installation Requirements

5.9.3.1 Technical Requirements for Boring

Contact Enbridge at crossingsUS@enbridge.com to obtain guidance as to the applicable technical requirements for your proposed drilling or boring activities.

Once the type of drilling or boring activity is determined, adhere to the following minimum clearance requirements:

- for horizontal directional drills (HDDs), 10 ft (3 m)
- for horizontal directional bores (HDBs), 3 ft (1 m), but can be reduced to 0.6 m (2 ft) providing:

- positive identification of the underground facility before digging
- positive identification (by slot hydrovac or hand excavation) confirms the position of the boring device and the installed foreign facility maintains a clearance of at least 0.6 m (2 ft) prior to intersecting the front edge of the Enbridge underground facility
- verification of the crossing consent that allowed the reduced clearance included an engineering review that determined there is no negative long-term impacts to the Enbridge facility

Note: The clearance is measured by the closest edge of the bore path (largest reamer used) to the closest edge of an Enbridge facility, which must be met when performing these activities.

5.9.3.2 Boring Operation General Requirements

Before beginning operations, applicants must ensure that:

- a boring plan and design are submitted with the application
- entry and exit angles are outside the Enbridge right-of-way
- boring equipment is secured or anchored to prevent movement

During operations, applicants must:

- continuously confirm the depth and alignment during the advancement of boring operations, including the reamed path or pilot hole
- use specialized mechanical equipment (e.g., hydraulic style tongs) to break the drill strings (when applicable for the boring type); use of manual tongs and/or excavator buckets is prohibited
- ensure all cables used to lift drill stems are inspected, in good condition, rated for the required load and free of knots (when applicable for the boring type)
- **not** do blind boring; both the Enbridge pipeline and the bore head must be positively identified (i.e., potholed) to verify clearances

5.9.4 Drainage Tile Crossing Enbridge Pipelines Requirements

Drain tile activities that meet the technical requirements below may be approved in the field using the “[Crossing and Encroachment On-Site Application and Consent](#),” otherwise the applicant needs to submit an application using the “[Crossing and Encroachment Application](#)”:

- 1 ft (0.3 m) vertical clearance for perpendicular pipeline
- 16 ft (5 m) or greater from the edge of the pipeline if parallel to the pipeline and outside the right-of-way
- equipment used must comply with vehicle crossing requirements and the location must comply with minimum clearance requirements

5.10 Above-Grade Installations

5.10.1 General Requirements for Above-Grade Installations

Above grade installations include such things as roads, railways, signs, fence posts and overhead power and communications lines.

Applicants must ensure for the following installations that:

- structures with underground supports, foundations, pilings or anchors (e.g., buildings or pools) are not installed within the Enbridge right-of-way or within 16 ft (5 m) of any Enbridge facility, whichever is the greater distance
- a minimum vertical clearance of 5 ft (1.5 m) for roadways, sidewalks and parking lots
- a minimum vertical clearance of 10 ft (3 m) for railways

For additional information, see other subsections below.

See Section 3.2.3, Typical Crossing Drawings, for a typical drawing of an above-ground installation (Figure 12: Above-Ground Installations – Typical Drawing).

Note: All activities that meet the requirements in Sections [5.10.2](#) to [5.10.11](#) may be approved in the field using the “[Crossing and Encroachment On-Site Application and Consent](#)”. Otherwise, the applicant needs to submit an application using the “[Crossing and Encroachment Application](#).”

5.10.2 Signs, Fence Posts and KP/MP Marker Installations

Requirements are that:

- posts, bars, rods or pins must not be installed within 5 ft (1.5 m) of the horizontal edge of an Enbridge facility
- fence crossings must be at an angle between 45–90 degrees (with preference for as close to perpendicular as possible)
- fences parallel to an Enbridge facility must be off the right-of-way and at least 10 ft (3 m) from an Enbridge facility
- masonry, brick, or stone fences are not permitted to be installed on any Enbridge right-of-way

See Figure 12: Above-Ground Installations – Typical Drawing in Section 3.2.3, Typical Crossing Drawings.

5.10.3 Resurfacing and Re-graveling

The minimum requirements for resurfacing and re-graveling of roads, pathways and sidewalks are:

- resurfacing with a maximum allowed milling/removal of 6” (0.15 m)
- resurfacing of up to 2 ft (0.6 m) of fill

See Section 3.2.3, Typical Crossing Drawings, for a typical resurfacing or re-graveling drawing (Figure 9: Resurfacing or Re-graveling – Typical Drawing).

5.10.4 Ditch Restoration

The minimum requirement for ditch restoration is that restoration must result in greater than 3 ft (0.9 m) depth of cover post remediation above the facility (excluding ditches in railway rights-of-way).

See Section 3.2.3, Typical Crossing Drawings, for a typical ditch restoration drawing (Figure 10: Ditch Restoration – Typical Drawing).

5.10.5 Minor Berms

Minimum requirements for minor berms are:

- up to 3 ft (1 m) high
- not to exceed total depth of cover of 7 ft (2.1 m) above a facility

See Section 3.2.3, Typical Crossing Drawings, for a typical minor berm drawing (Figure 11: Minor Berms – Typical Drawing.)

5.10.6 Spreading or Replacing Soil Fill Material

Minimum requirements for spreading or replacing soil fill material are:

- less than 3 ft (1 m) depth of additional soil and not to exceed a total depth of cover of 7 ft (2.1 m) above a pipeline
- soil fill material spread on land that is not on a slope
- equipment used must comply with vehicle crossing requirements and no excavation is involved

5.10.7 Topsoil Stripping/Leveling and Clearing/Grading

Topsoil stripping/leveling and clearing/grading activities require Enbridge review and approval.

5.10.8 Ancillary Installation, Above-Ground Installation or Temporary Storage

When a parcel size and proximity of houses limits the ability to access the right-of-way and/or limits the ability of the landowner to place a private facility or encroachment off the right-of-way, Enbridge might allow upon approval. For more information, contact crossingsUS@enbridge.com.

5.10.9 Agricultural Ground Disturbance

Operation of agricultural vehicles or mobile equipment across a pipeline for the purposes of performing an agricultural activity can be performed without written consent from Enbridge provided:

- the loaded axle weight and tire pressures of the vehicle or mobile equipment are within the manufacturer's approved limits and operating guidelines
- the point of crossing has not been the subject of a notification from Enbridge that crossing at that location could impair the pipeline's safety or security
- cultivation is less than 1.5 ft (0.45 m) deep below the surface
- soil disturbance is less than 30 cm (1 ft) deep if it does not reduce the earth cover over the pipeline below the level when the pipeline was constructed

Agricultural activities that do not meet the above conditions can receive approval upon an application for consent.

5.10.10 Vegetation Control

Minimum requirements for vegetation control are that:

- equipment used must comply with vehicle crossing requirements
- burning, brushing, tree clearing and stump grinding of existing vegetation growing on the right-of-way is permissible if it complies with crossing requirements, and any ground disturbance is no more than 1 ft (0.3 m) deep, and stays 3 ft (1 m) horizontally from the outer diameter of the Enbridge facility
- removal of root systems of trees that are less than 5 ft (1.5 m) tall and are located within the ground disturbance zone (see Section [2.4](#)) but more than 10 ft (3 m) from an Enbridge facility

Note that removal of the root system might have to be completed by an Enbridge approved contractor at the cost of the applicant as the removal might negatively impact the integrity of the facility.

5.10.11 Temporary Equipment Crossings – Wheeled and Tracked Vehicles

Operation or movement of highway permissible vehicles, mobile equipment or machinery across an Enbridge right-of-way, on the travelled portion of a highway or public road do not require assessment.

Minimum requirements for on-site consent for temporary vehicle crossings are that:

- where there is a confirmed depth of cover of at least 4 ft (1.2 m):
 - wheeled vehicles must weigh less than 20,000 lb (9,072 kg) per axle
 - tracked vehicles must weigh less than 20,000 lb (9,072 kg) total weight
- where there is a confirmed depth of cover of at least 10 ft (3 m):
 - wheeled vehicles must weigh less than 56,000 lb (25,400 kg) per axle
 - tracked vehicles must weigh less than 60,000 lb (27,270 kg)
- applicants must stay 16 ft (5 m) away from Enbridge facilities at all times, except at the approved temporary equipment crossing location
- the approved temporary crossing location must be over straight pipeline only and to a maximum width of 25 ft (8 m) on either side of the specified GPS coordinates

Note that some regions might have more stringent weight requirements for specific pipelines than noted above.

Equipment that has been previously approved might be eligible for preapproval for future use.

For all other equipment that cannot be approved by on-site consent, submit a “[Crossing and Encroachment Application](#)” through the Crossings department.

See Section 5.7.4, Temporary Crossing Ramps and Air Bridges, for alternative vehicle-crossing technical requirements.

See Section 3.2.3, Typical Crossing Drawings for additional wheeled and tracked vehicle information requirements (Figure 13: Tracked Vehicles – Typical Drawing and Figure 14: Wheeled Vehicles – Typical Drawing).

5.10.12 Road Crossings

Enbridge should be contacted as early as possible, either during the concept or planning stages of a road crossing that may cross or impact an Enbridge right-of-way. Early notification will ensure Enbridge can:

- properly assess the impact on safety, the environment and assets
- complete required engineering assessments so that recommendations can be incorporated into the design
- complete any mitigative work in time to avoid impacting construction schedules

See Section 3.2.3, Typical Crossing Drawings, for a typical road-crossing drawing (Figure 2: Road Crossing – Typical Drawing).

5.10.13 Railway Crossings

Enbridge should be contacted as early as possible, either during the concept or planning stages of a railway crossing that may cross or impact an Enbridge right-of-way. Early notification will ensure Enbridge can:

- properly assess the impact on safety, the environment and assets
- complete required engineering assessments so that recommendations can be incorporated into the design
- complete any mitigative work in time to avoid impacting construction schedules

See Section 3.2.3, Typical Crossing Drawings, for a typical railway crossing drawing (Figure 5: Railway Crossing – Typical Drawing).

5.11 Power and Communication Installations

5.11.1 Consent Limitation

Changes in power line operating characteristics or configuration that are outside the parameters of the original power line consent (e.g., increased maximum load, introducing or removing a phase transposition) must be reported to Enbridge for assessment.

5.11.2 Overhead Power Less Than 60 kV and Communication Installation

Technical Requirements

Note, for power lines 60 kV or higher, see the section below for transmission power.

Minimum requirements for overhead power lines less than 60 kV and communication lines are that:

- pole placement for overhead power lines and associated appurtenances, telephone lines and telecommunication installations:
 - if the Enbridge facility is a transmission pipeline:
 - must be outside of the Enbridge right-of-way or at least 33 ft (10 m) horizontally away from any Enbridge facility, whichever is the greater distance
 - if the Enbridge facility is a gas distribution pipeline:
 - the clearance distance may be less than 33 ft (10 m) but kept as far away as practicable
 - the minimum required safe clearances for power lines based on operating voltage provided in Table 3 should be maintained
- minimum vertical clearance must be 25 ft (8 m) from the top of grade to any cable or lines crossing the right-of-way along with any associated appurtenances

Table 3: Overhead AC Distribution Power Line Horizontal Clearances for Distribution Pipelines

System Voltage (kV)	Minimum Horizontal Clearance Distance*	
	m	ft
<=12.8	0.3	1
<=14.4	0.4	1.2
<=16.6	0.6	1.8
<=25	1.3	4.1
<=45	2.9	9.5
<60	4.2	13.5

*Note: These distances are conservative and assume that the power line structure reaches the phase-to-ground voltage of the power line. Where these clearances cannot be maintained, smaller distances

System Voltage (kV)	Minimum Horizontal Clearance Distance*	
	m	ft
might be acceptable, if modeling and additional calculations demonstrate that the arcing risk is negligible.		

Field Approved Activities

Pole placement for overhead power lines and associated appurtenances, telephone lines and telecommunication installations may be approved in the field using the “Crossing and Encroachment On-Site Application and Consent” if the proposed installation meets the technical requirements above and subject to the following conditions, if applicable:

- for transmission and distribution pipelines: power lines must be less than 330 ft (100 m) of continuous parallel lines to the pipeline for clearances of less than 160 ft (50 m) from the center line of the pipeline
- for distribution pipelines: for power lines less than 12.8 kV and communication lines, a minimum clearance of 1 m (3 ft) should be maintained where possible, but no less than 1 ft (0.3 m). Less than 3 ft (1 m) would be acceptable only with the following mitigation measures:
 - signage must be installed on each pole on the side facing the gas main warning that there is a gas main in close proximity and no ground disturbance (or ground rods) are allowed on this side
 - ground rods or any potential grounding points, e.g., anchors, (if required) should be installed on the opposite side of the pole from the pipeline, if possible

5.11.3 Power Line Data Requirements for Transmission Power

5.11.3.1 Power Lines More Than 60 kV

Application Requirements

Applicants must submit a “Crossing and Encroachment Application” if a power line:

- is equal to or more than 60 kV and encroaches within the right-of-way or crosses the pipeline
- is equal to or more than 60 kV and is paralleling the pipeline for more than 100 m (330 ft) and has a horizontal clearance of less than 500 m (1640 ft) from the pipeline
- is a DC power line

Safe Clearances

The minimum safe horizontal clearance distances between a pipeline and power line structures, grounding and anchors to avoid arcing risks are as follows:

- if the Enbridge facility is a transmission pipeline:
 - power line structures, grounding and anchors must be outside of the Enbridge right-of-way and at least 33 ft (10 m) away from any Enbridge facility, whichever is the greater distance
- if the Enbridge facility is a gas distribution pipeline:

Crossing and Encroachment Guide and Requirements – US



- the clearance distance may be less than 33 ft (10 m) but kept as far away as practicable
- the minimum required safe clearances for power line structures, grounding and anchors based on operating voltage provided in Table 4 should be maintained
- minimum vertical clearance for all pipelines must be 25 ft (8 m) from the top of grade to any cable or lines crossing the right-of-way along with any associated appurtenances

Table 4: High-Voltage AC Power Line Horizontal Clearances from Structures, Grounding and Anchors for Distribution Pipelines

System Voltage (kV)	Minimum Horizontal Clearance Distance ^{1,2}			
	Power Line with Shield Wires		Power Line without Shield Wires	
	m	ft	m	ft
60	4.2	13.5	4.2	13.5
<=69	5	16	5	16
<=115	9	29	9	29
<=144	10	33	12	37
<=240	10	33	19	62
<=345	10	33	28	91
<=500	10	33	41	133
<=735	10	33	60	196
>735	Requires review		Requires review	

Notes:

1. Structures must be outside of the right-of-way and meet the minimum clearances from the pipeline as set forth in this table.
2. These distances are conservative and assume that the power line structure (without shield wires) reaches the phase-to-ground voltage of the power line. Where these clearances cannot be maintained, smaller distances may be acceptable, if an engineering assessment including modeling and additional calculations demonstrate that the arcing risk is negligible.

5.11.3.2 Information Required for Each Transmission Power Line

The following information is required for each transmission power line equal to or greater than 60 kV near an Enbridge pipeline.

Items to Include on Overhead Transmission Power Drawings

Power circuit number, ID number and name:

System voltage (line to line):

- Staking list showing chainages and GPS coordinates of all structures: from substation to substation for *parallel studies, and at least five structures upstream and downstream of crossing locations without *parallel.

Items to Include on Overhead Transmission Power Drawings

- Cross-section drawings of the power lines structures, showing the positions of all conductors (phase conductors, shield wires), including:
 - vertical and horizontal clearance between conductors
 - average height of conductors, or height of conductors at the tower and at mid-span
 - circuits and phase arrangement for each circuit (i.e., A-B-C top-bottom)Please indicate the direction looking at the structure at each cross-section
- Shield wire information:
 - # of shield wires
 - shield wire size, type (material)
 - shield wire resistance, (ohm/unit length)
 - continuous or segmented
 - continuous with substation grounding at extremities
- Tower grounding:
 - typical grounding details (drawing or sketch), if grounding electrodes are used
 - tower foundation details (suspension towers only), to estimate the resistance of the “natural grounding” provided by the tower foundation
 - grounding resistance of each tower, if known, or an average grounding resistance
 - details of counterpoise, if any
 - details of guy wire anchors, if any
- Locations and details of any phase transpositions along the common right-of-way (pipeline chainage or GPS coordinates of the transposition towers or marking on the drawings). Please indicate the phase arrangement at each transposition tower.
- Phase current loading:
 - peak annual
 - peak projected
 - average annual
 - average projected
 - emergency
- Line-to-ground fault currents:
 - a. at beginning of common right-of-way:
 - total fault current
 - fault current contributions from the north/east
 - fault current contributions from the south/west
 - b. at middle of common right-of-way:
 - total fault current
 - fault current contributions from the north/east
 - fault current contributions from the south/west
 - c. at end of common right-of-way:
 - total fault current
 - fault current contributions from the north/east
 - fault current contributions from the south/west
- Line-to-ground fault duration:

Items to Include on Overhead Transmission Power Drawings

- minimum (primary protection)
- maximum (backup protection)
- Substation layout drawings and grounding impedances at both ends of each transmission line circuit, if available.

* “Parallel” refers to the pipeline(s) and power line(s) situated side-by-side or low angle (<45 degree) crossings with a clearance distance of 2461 ft (750 m) or less.

5.12 Geophysical – Blasting, Quarrying and Seismic

Applicants must notify Enbridge of any geophysical activities occurring within 985 ft (300 m) of the pipeline right-of-way so that Enbridge can review the proposed plans to see if there might be potential impacts to its facilities.

An applicant’s failure to consult Enbridge before beginning activities requiring the use of explosives (i.e., blasting/seismic exploration) within 985 ft (300 m) of a pipeline right-of-way might result in damages to Enbridge facilities, the public, environment and/or property for which the applicant might be held liable.

Contact Enbridge for additional application requirements (see Section 3.2.2i) Blasting – Including Seismic and Geophysical Activities).

5.13 Site Restoration Requirements

Applicants must ensure that:

- no trees with mature height exceeding 5 ft (1.5 m) are allowed within an Enbridge right-of-way or within 25 ft (8 m) of any Enbridge facility, whichever is the greater distance
- the site is restored to as close as practical to its original condition, except for expressly agreed upon exceptions
- unless approved by Enbridge, no reduction in final grade or drainage alteration over any Enbridge facility is permitted
- all landscaping within any Enbridge right-of-way needs to be approved by Enbridge before installation

6 Emergency Situations and Enbridge Emergency Contact Numbers

6.1 Notice of Access

In an emergency, please provide Enbridge with as much notice of access to the emergency site as practicable before beginning any construction, excavation, installation or temporary activities affecting existing pipelines and/or rights-of-way.

6.2 Enbridge Definition of Emergency

Enbridge classifies an emergency as:

- a risk to human life
- required emergency repairs of public services
- containment of an environmental emergency

Crossing and Encroachment Guide and Requirements – US



6.3 One-Call Centers

In an emergency, contact your local One-Call provider at the numbers listed in Section 4, Requirements Before Construction – One-Call Centers and Locate Requests.

6.4 Enbridge Emergency Contact Numbers

Also contact Enbridge at the following emergency contact numbers.

Table 5: Enbridge Crude Oil and Liquids Emergency Numbers for the US

US	
Illinois, Indiana, Kansas, Michigan, Minnesota, Missouri, North Dakota, Ohio, Oklahoma, Wisconsin	1 (800) 858-5253
Express U.S. and Platte (Montana, Wyoming, Nebraska, Kansas, Missouri)	1-888-449-7539

Table 6: Enbridge Gas and Midstream Emergency Numbers for the US

US	
Algonquin Gas Transmission	1-800-726-8383
Big Sandy Pipeline	1-800-231-3217
Bobcat Storage Operations	1-337-585-0526
Dauphin Island Gathering Partners/DCP Midstream Gas Control	1-888-204-1781
East Tennessee Natural Gas	1-888-231-2294
Gulfstream	1-800-440-8475
Maritimes & Northeast Pipeline	1-888-576-4634
Market Hub Partners (Egan, Louisiana)	1-337-824-6100
Market Hub Partners (Moss Bluff, Texas)	1-936-336-8761
NEXUS Gas Transmission	1-855-329-1781
Ozark Gas Transmission/Ozark Gas Gathering	1-877-535-0242
Sabal Trail	1-888-568-7269
Southeast Supply Header (SESH)	1-866-977-7374
Steckman Ridge	1-800-231-7794
Texas Eastern Transmission	1-800-231-7794

Table 7: Enbridge Renewable Power and Power Transmission Emergency Numbers for the US

US	
24 hours, toll free	1-866-420-6630
MATL (Western Montana)	1-888-780-8831

7 Definitions

Applicant – A facility owner, a company, a person, a municipality or government body requesting consent.

Facility – Any structure, public or private road, railway, irrigation ditch, drain, drainage system, sewer, dike, telephone line, telegraph line, telecommunication line and line for the transmission of electricity or pipe for the transmission of hydrocarbons or any other substance.

Horizontal Directional Bore (HDB) – Contact crossingsCanada@enbridge.com or crossingsUS@enbridge.com to obtain the Crossing and Encroachment Guide and Requirements- Drilling and Boring document that is applicable to the business unit that the Activity/Work affects.

Horizontal Directional Drill (HDD) – Contact crossingsCanada@enbridge.com or crossingsUS@enbridge.com to obtain the Crossing and Encroachment Guide and Requirements- Drilling and Boring document that is applicable to the business unit that the Activity/Work affects.

Jack and Bore – Auger Boring – Contact crossingsCanada@enbridge.com or crossingsUS@enbridge.com to obtain the Crossing and Encroachment Guide and Requirements- Drilling and Boring document that is applicable to the business unit that the Activity/Work affects.

Method of Installation – The process by which the proposed permanent installation will be constructed.

Minimum Clearance – The minimum distance acceptable between an existing facility and the proposed facility based on the selected method of installation.

Non-Road Legal Vehicle – A vehicle that is not equipped and licensed for use on public roads.

Open Cut – A trench methodology wherein access is gained to the required level underground for the proposed installation, maintenance or inspection of a facility. The excavated trench is then backfilled and the surface restored.

Permanent Installation – An installation that will remain in place for the life of the facility.

Pile Drive – The installation of a deep foundation unit (i.e., pile) by dropping a rig- or truck-mounted hydraulic hammer repeatedly on the pile head to advance it into the ground, or using a vibratory-type installation method.

Preliminary Design – Initial inquiry by an applicant to Enbridge in order to obtain relevant information about Enbridge facilities to be used during the design phase of the applicant's proposed permanent installation and/or temporary activities.

Right-of-Way (ROW) – The area of land defined in the easement agreement for the purpose of construction, operation and maintenance of a facility.

Road Legal Vehicle – A vehicle that is equipped and licensed for use on public roads.

Road Use – Temporary or permanent use of an industry-owned road, which may include road use fees.

Temporary Access – Temporary surface use by the applicant of an Enbridge right-of-way that travels parallel to an existing pipeline or on fee-simple land owned by Enbridge in order to travel to a construction or work site.

Temporary Activities – An activity with a set expiry date.

Temporary Equipment/Vehicle Crossing – Temporary surface crossing of an existing Enbridge facility by equipment or vehicles.

Crossing and Encroachment Guide and Requirements – US



Temporary Protective Structure - A structure or device designed to provide protection to workers, adjacent structures, excavations, tunnels and or underground shafts from sliding or rolling materials, cave-ins and/or collapses, e.g., trench boxes, shoring, bracing, piles, timbers and cages.

Temporary Workspace – Temporary surface use over an existing facility or right-of-way for construction purposes.